

ITEM NO.	DESCRIPTION	QTY.
1.01	Dynamic De-heading Table	1
1.02	Infeed Buffer Table	1
1.03	BE-5351 Compact Pro Filleting Machine	1
1.04	Goose neck conveyor	1
1.05	2-Lane Trimming Line	1
1.06	Goose neck conveyor	1
1.07	Trolley 200L	2

Unless otherwise specified, all dimensions are in mm. and tolerances according to ISO 2768-1m
 General welding tolerance: DS/EN ISO 13920 - B
 This drawing is the property of Beritech A/S and may not be handed over to a third part, copied or in any other way applied without our authorization

BERITECH

Charge:		Drawn date: 2025-04-07	Description Layout 4 - Filleting line up to 20 fish/min	
Drawn by: jbg	Edited by:	Weight (kg): 8263.65	Description 2 Segment	
Material:	Scale: 1:100	Format: A3	File no.: 80079116	Rev.: A

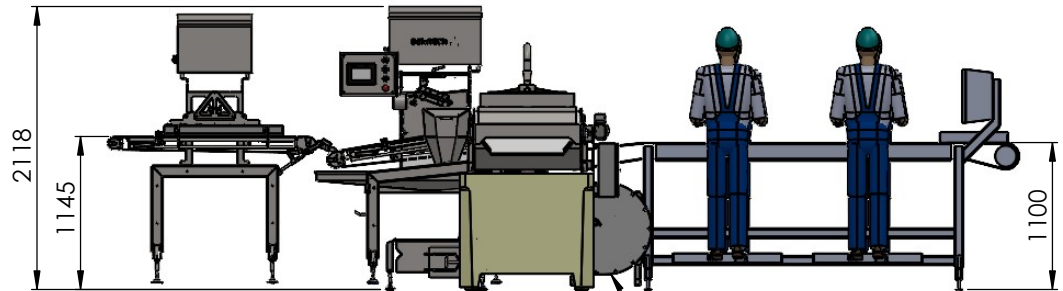

6814

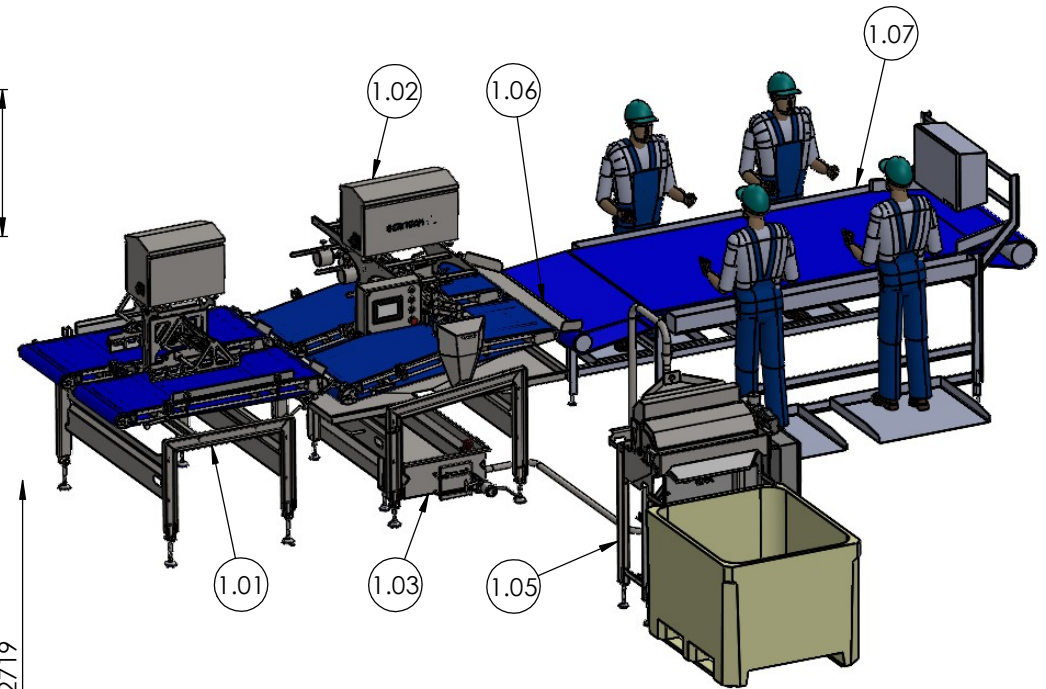
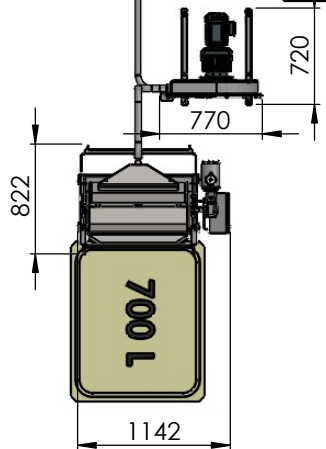
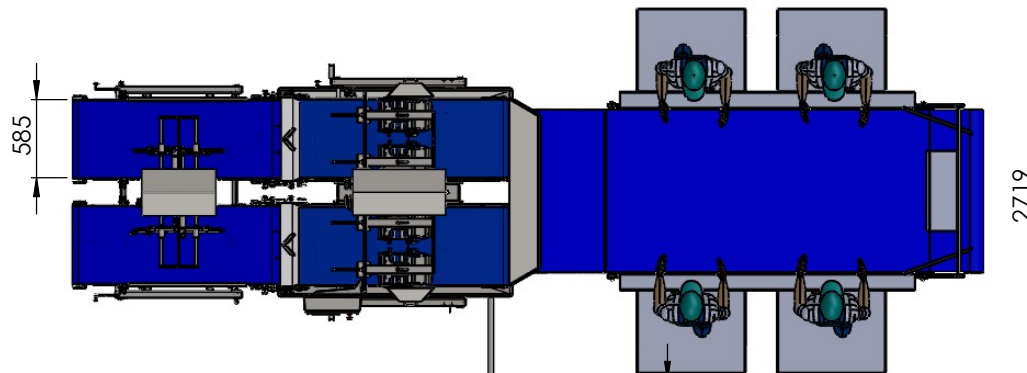

ITEM NO.	DESCRIPTION	QTY.
1.01	BE-5601 Fillet distributor	1
1.02	BE-5521 Pinbone Remover 4-Lane	1
1.03	Vessel for filter system	1
1.04	Hose pump	1
1.05	Filter unit	1
1.06	Chute after 4 lane Pb	1
1.07	Pin bone check	1

<small>Unless otherwise specified, all dimensions are in mm. and tolerances according to ISO 2768-1m General welding tolerance: DS/EN ISO 13920 - B</small>		Charge: 2025-04-02	Drawn date: 2025-04-02	Description Layout 7 - Pinbone line up to 20 fish/min	
<small>This drawing is the property of Beritech A/S and may not be handed over to a third part, copied or in any other way applied without our authorization.</small>		Drawn by: jbg	Edited by:	Weight (kg): 4635.74	Description 2
BERITECH		Material:	Scale: 1:50	Format: A3	File no.: 80078649
					Rev.: A

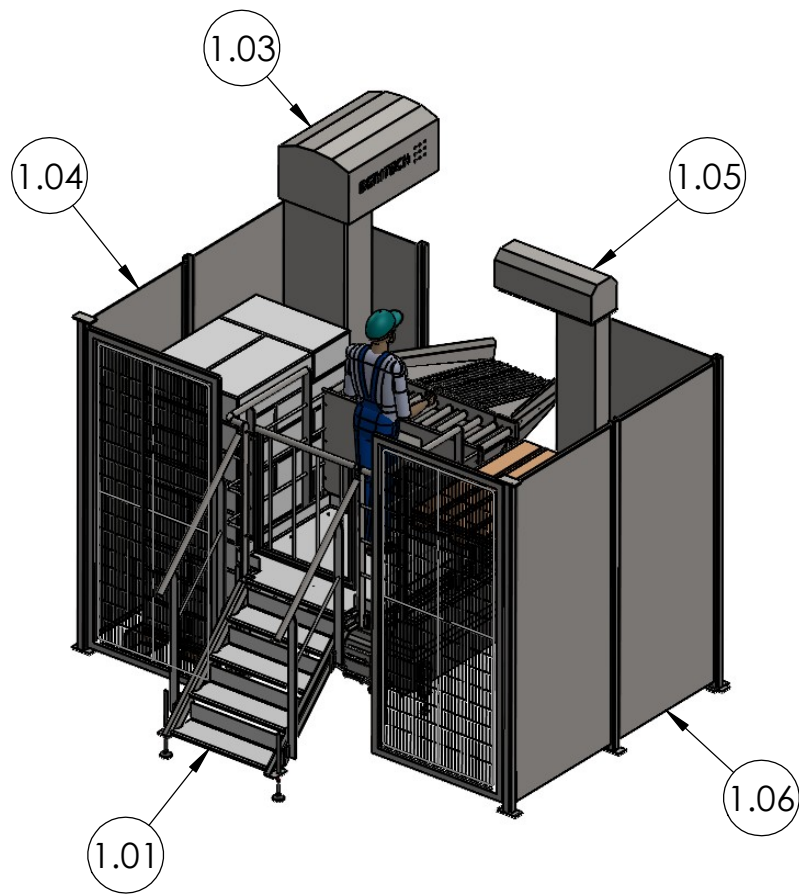
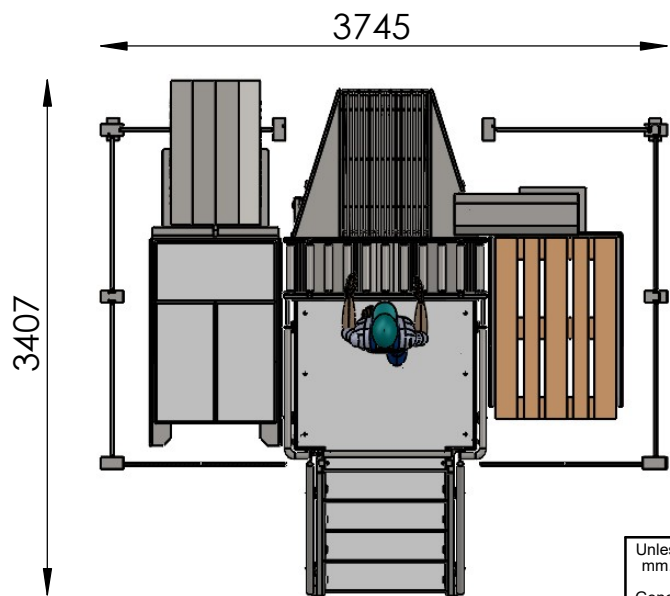
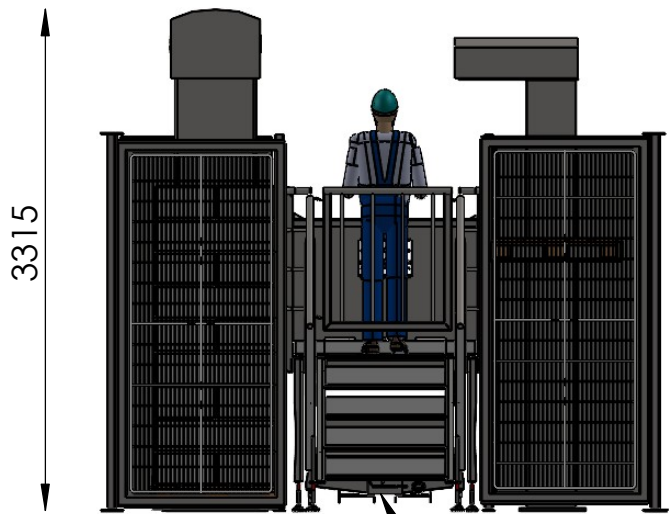

ITEM NO.	DESCRIPTION	QTY.
1.01	De-icing	1
1.02	Melting unit	1
1.03	CL1000 Column loader for EUR pallets	1
1.04	Safety Fence - Left (L1000)	1
1.05	Column loader CL300	1
1.06	Safety Fence - Right (L300)	1

Unless otherwise specified, all dimensions are in mm. and tolerances according to ISO 2768-1m
 General welding tolerance: DS/EN ISO 13920 - B

This drawing is the property of Beritech A/S and may not be handed over to a third part, copied or in any other way applied without our authorization

BERITECH

Charge:

Drawn date:
2026-01-15

Description
Layout 8 - Deicing of boxes

Drawn by:
jbg

Edited by:
jbg

Weight (kg):
23740.57

Description 2
Segment

Material:
Material <not specified>

Scale:
>1:100

Format:
A4

File no.:
80104893

Rev.:
A

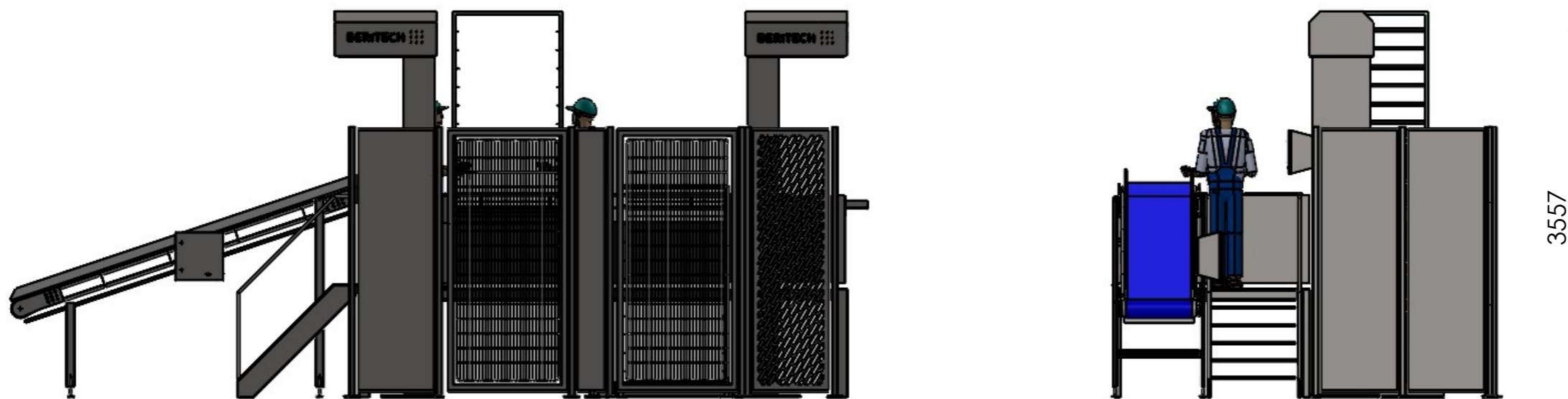

Different types of safety fence can be supplied
(flat stainless plate, wire mesh or perforated plate)

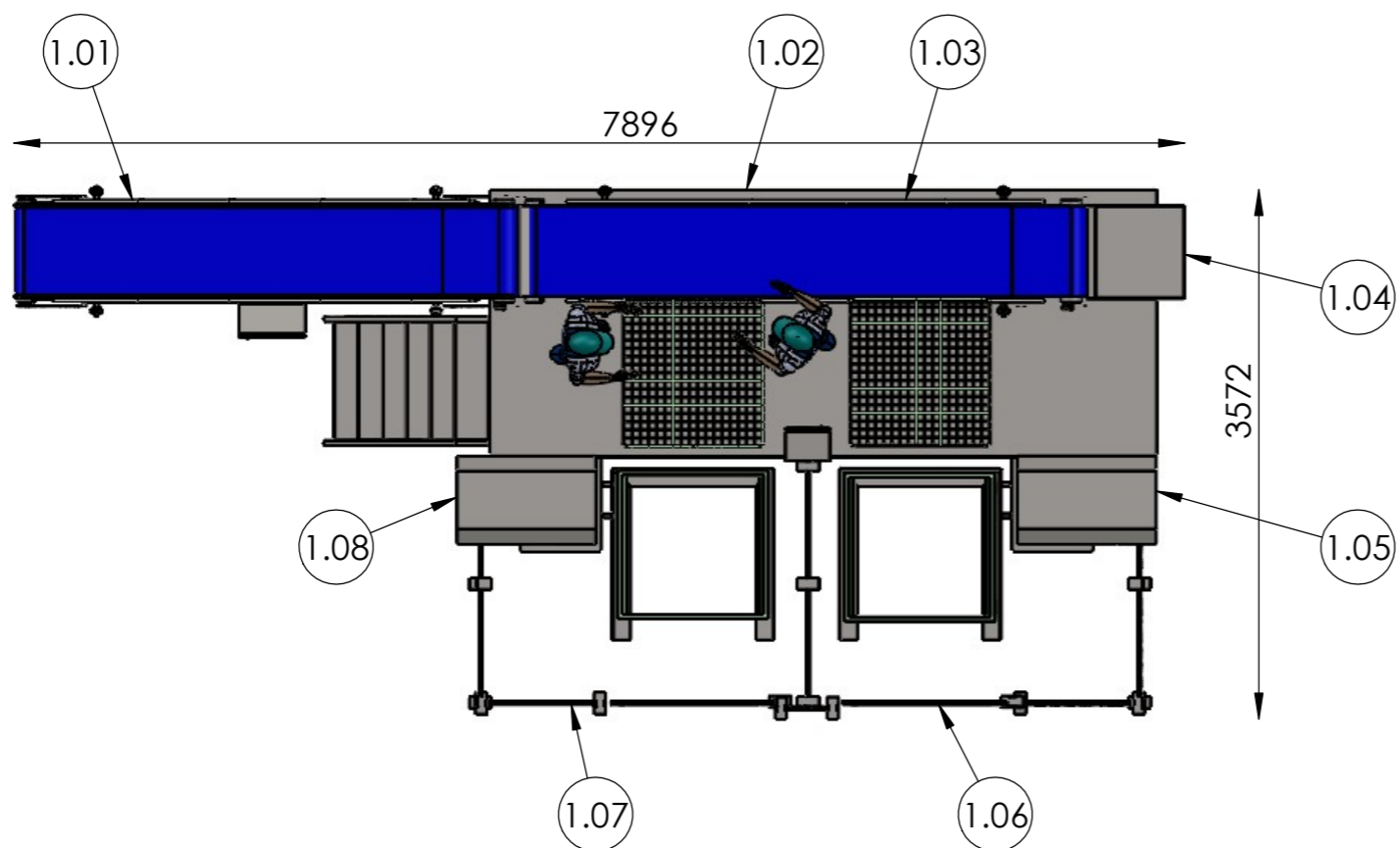

ITEM NO.	DESCRIPTION	QTY.
1.01	Conveyor Incline	1
1.02	Platform for smoke fillet loading	1
1.03	Conveyor	1
1.04	Buffer for conveyor	1
1.05	Column loader CL1000	1
1.06	Safety fence	1
1.07	Safety fence	1
1.08	Column loader CL1000	1

Finish	Polished	
	Pickled	
Foil	Inside	
	Outside	
Deburr		X

Notes

Proven Conzept Layout - Salmon.

Unless otherwise specified, all dimensions are in mm. and tolerances according to ISO 2768-1m
General welding tolerance: DS/EN ISO 13920 - B
This drawing is the property of Beritech A/S and may not be handed over to a third part, copied or in any other way applied without our authorization



Charge:

Drawn by: jbg Edited by: jbg

Material:

Drawn date: 2024-04-10

Weight (kg): 15277.01

Scale: 1:200 Format: A3

Description: Layout 9 - Smoke Trolley Loading

Description 2: Segment

File no.: 80041994 Rev.: A

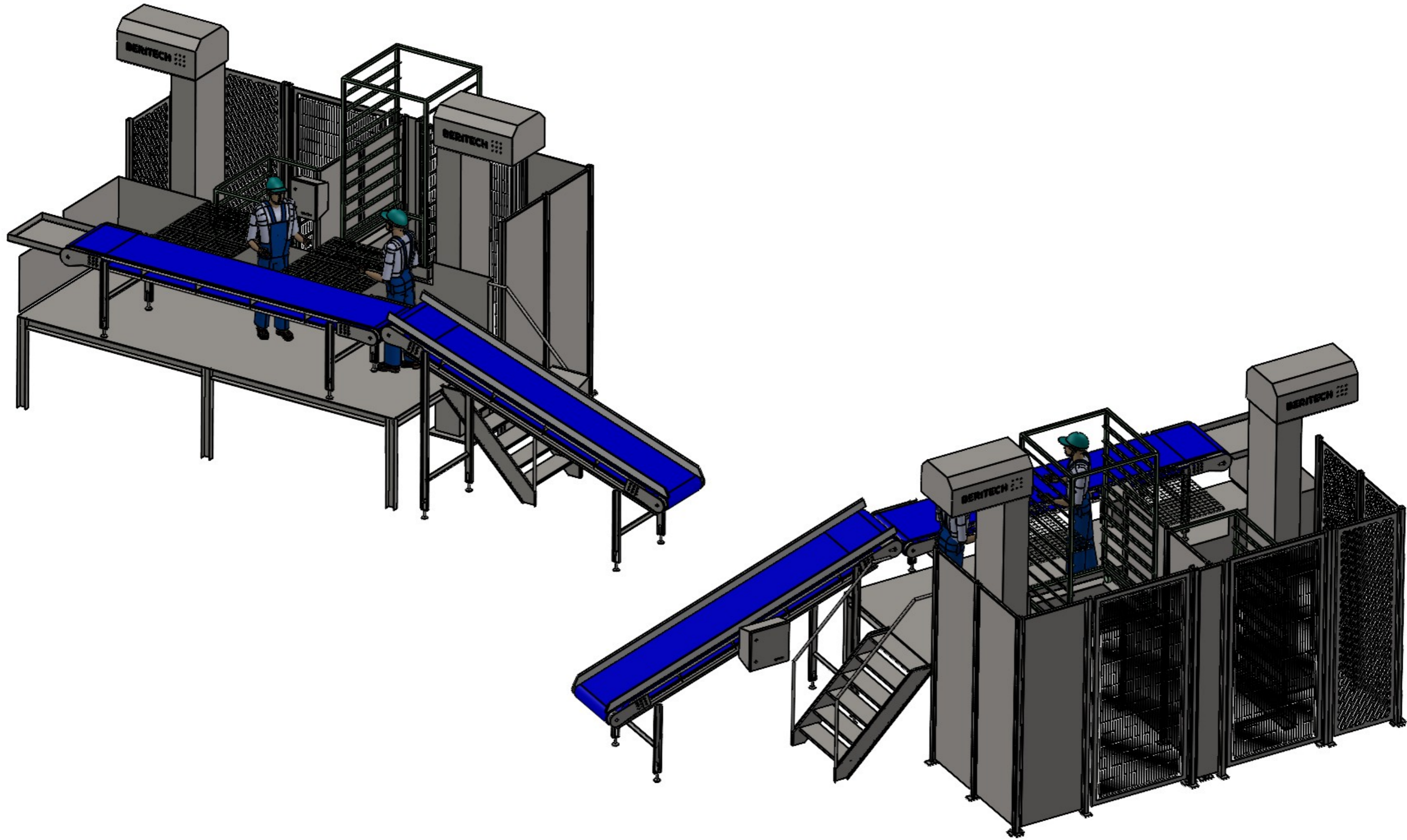

Different types of safety fence can be supplied (flat stainless plate, wire mesh or perforated plate)

<small>Unless otherwise specified, all dimensions are in mm. and tolerances according to ISO 2768-1m General welding tolerance: DS/EN ISO 13920 - B This drawing is the property of Beritech A/S and may not be handed over to a third part, copied or in any other way applied without our authorization</small>	Charge:		Drawn date: 2024-04-10	Description Layout 9 - Smoke Trolley Loading	
	Drawn by: jbg	Edited by: jbg	Weight (kg): 15277.01	Description 2 Segment	
	Material:		Scale: 1:200	Format: A3	File no.: 80041994



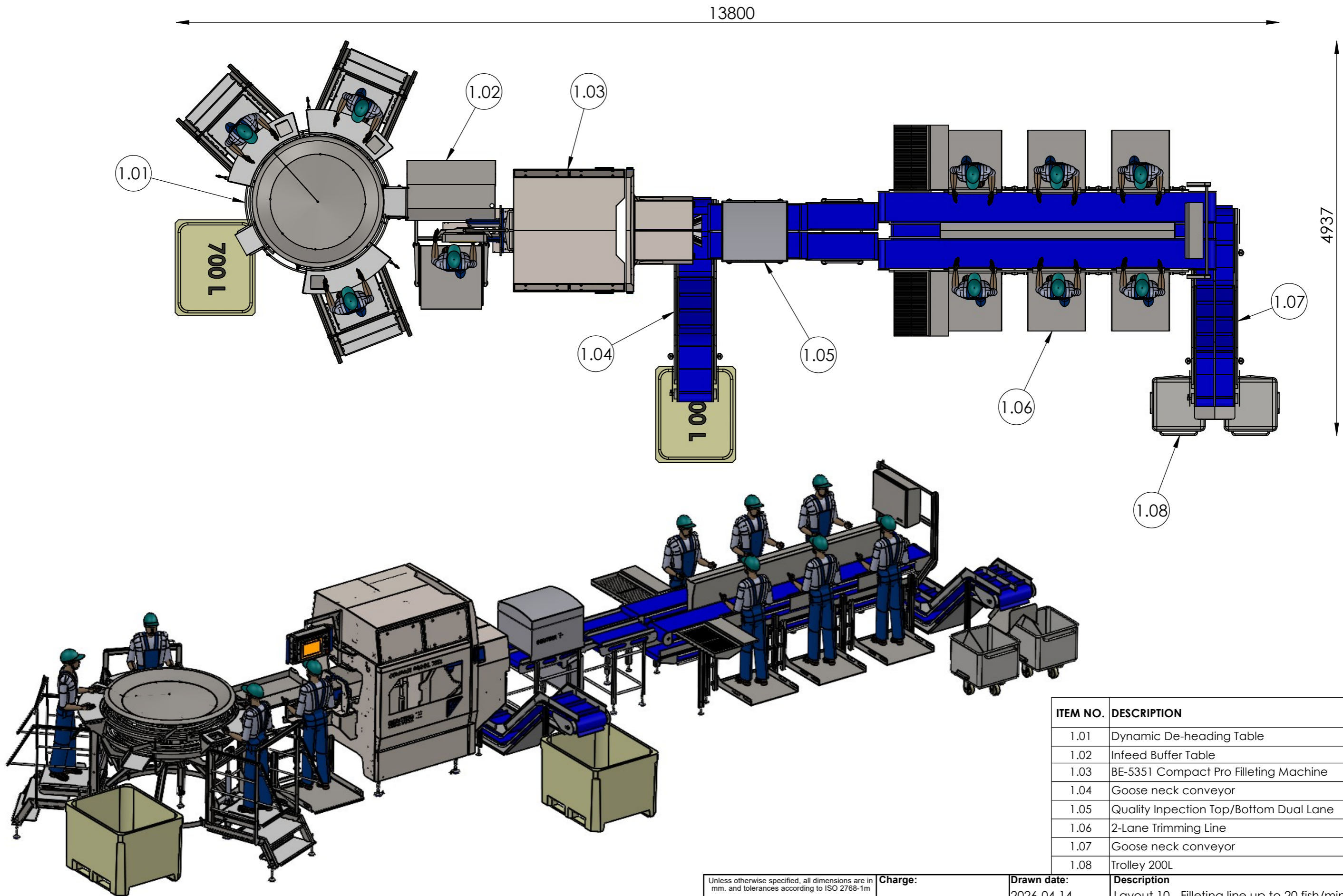

ITEM NO.	DESCRIPTION	QTY.
1.01	Dynamic De-heading Table	1
1.02	Infeed Buffer Table	1
1.03	BE-5351 Compact Pro Filleting Machine	1
1.04	Goose neck conveyor	1
1.05	Quality Inspection Top/Bottom Dual Lane	1
1.06	2-Lane Trimming Line	1
1.07	Goose neck conveyor	1
1.08	Trolley 200L	2

<small>Unless otherwise specified, all dimensions are in mm. and tolerances according to ISO 2768-1m General welding tolerance: DS/EN ISO 13920 - B This drawing is the property of Beritech A/S and may not be handed over to a third part, copied or in any other way applied without our authorization</small>	Charge:		Drawn date: 2026-04-14		Description Layout 10 - Filleting line up to 20 fish/min with QC	
	Drawn by: jbg	Edited by: jbg	Weight (kg): 8561.87		Description 2 Segment	
	Material: Material <not specified>		Scale: >1:100	Format: A3	File no.: 80113562	Rev.: A

