

11871

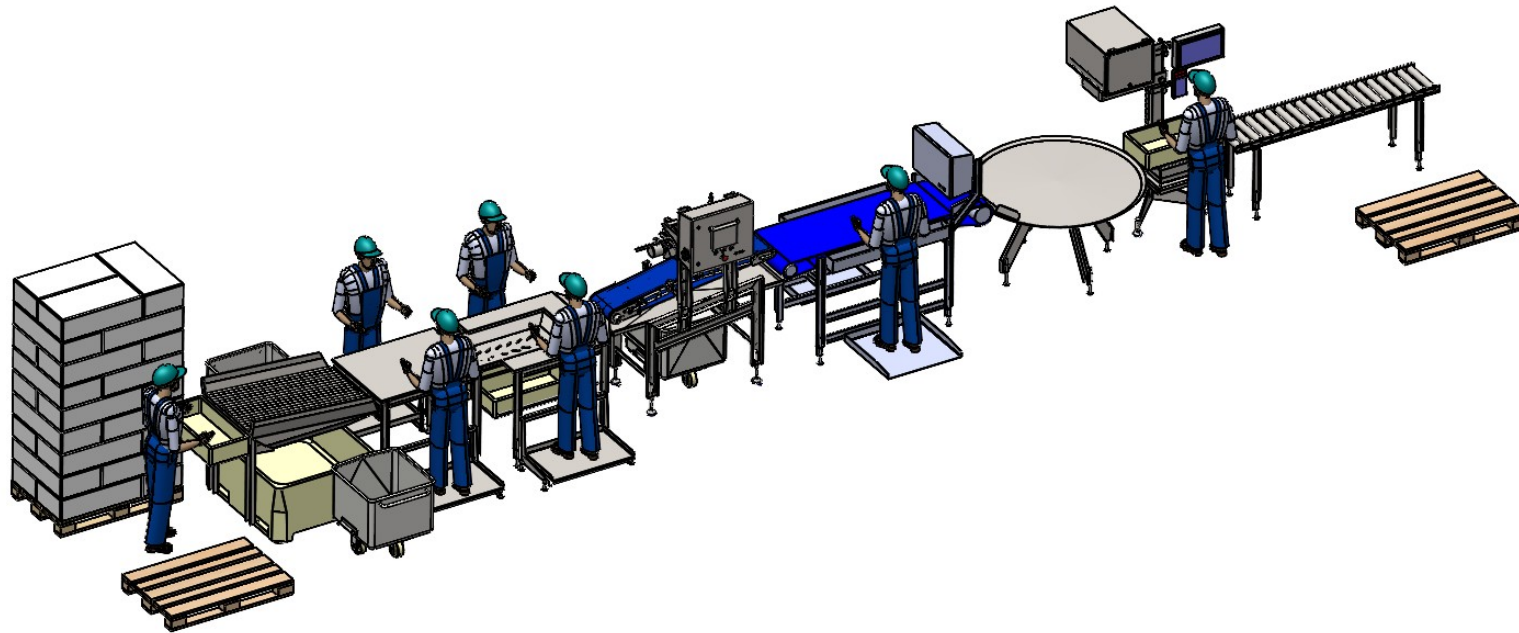
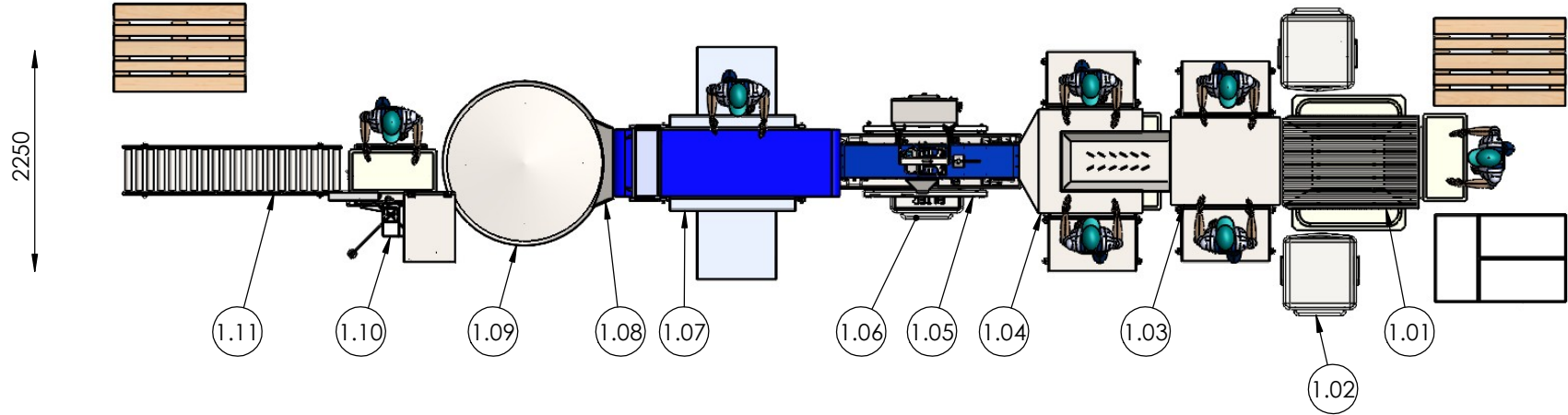

ITEM NO.	DESCRIPTION	QTY.
1.01	Custom Deicing	1
1.02	Trolley 200L	2
1.03	De-heading table	1
1.04	Trimming Table	1
1.05	Pinbone Remover BE-5501 One Lane	1
1.06	Filter trolley 200L	1
1.07	Pin bone check	1
1.08	Chute for round table	1
1.09	Rotating table ø1500	1
1.10	Man Packing Station - Custom	1
1.11	Roller lane	1

Finish	Polished
	Pickled
Foil	Inside
	Outside
Deburr	

Notes

Proven Conzept Layout - Salmon.

Unless otherwise specified, all dimensions are in mm. and tolerances according to ISO 2768-1m
 General welding tolerance: DS/EN ISO 13920 - B
 This drawing is the property of Beritech A/S and may not be handed over to a third part, copied or in any other way applied without our authorization.

BERITECH

Charge:		Drawn date:		Description	
		2024-01-22		Layout 1 - Filleting line up to 5 fish/min.	
Drawn by:	Edited by:	Weight (kg):		Description 2	
jbg	jbg	21133.99		into boxes	
Material:		Scale:	Format:	File no.:	Rev.:
		1:100	A3	80034757	A

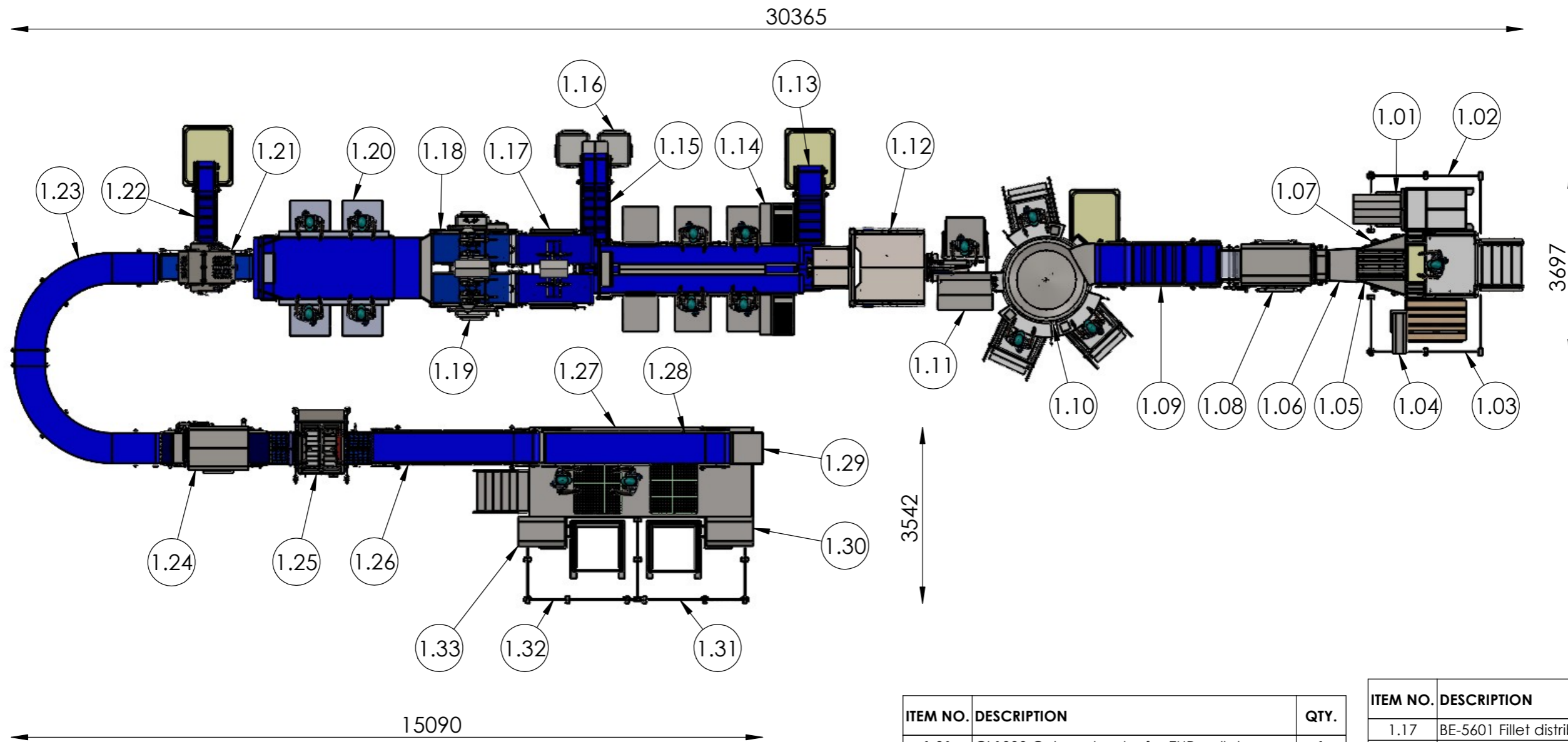

ITEM NO.	DESCRIPTION	QTY.
1.01	CL1000 Column loader for EUR pallets	1
1.02	Safety Fence Right	1
1.03	Safety Fence - Left	1
1.04	Column loader CL300	1
1.05	De-icing	1
1.06	Chute whole fish	1
1.07	Melting unit	1
1.08	Deslimer	1
1.09	Goose neck conveyor	1
1.10	DeHeading Table	1
1.11	Infeed Buffer Table	1
1.12	BE-5351 Compact Pro Filleting Machine	1
1.13	Goose neck conveyor	1
1.14	2-Lane Trimming Line	1
1.15	Goose neck conveyor	1
1.16	DIN 9797 trolley 200L	2

ITEM NO.	DESCRIPTION	QTY.
1.17	BE-5601 Fillet distributor	1
1.18	BE-5521 Pinbone Remover 4-Lane	1
1.19	Filter Trolley 200L	2
1.20	Pin bone check	1
1.21	Beritech Salmon Skinner	1
1.22	Goose neck conveyor	1
1.23	One curved conveyor Left	1
1.24	Fillet Washer	1
1.25	Dual lane dry-salting unit	1
1.26	Conveyor	1
1.27	Platform for smoke fillet loading	1
1.28	Conveyor	1
1.29	Buffer for conveyor (fillet loading)	1
1.30	Column loader CL1000	1
1.31	Safety fence	1
1.32	Safety fence	1
1.33	Column loader CL1000	1

Finish	Polished	
	Pickled	
Foil	Inside	
	Outside	
Deburr		X

Proven Conzept Layout - Salmon.

Notes

Unless otherwise specified, all dimensions are in mm. and tolerances according to ISO 2768-1m
 General welding tolerance: DS/EN ISO 13920 - B
 This drawing is the property of Beritech A/S and may not be handed over to a third part, copied or in any other way applied without our authorization

BERITECH

Charge:
 Drawn by: jbg
 Edited by: jbg

Drawn date:
 2024-01-03
 Weight (kg):
 53180.41

Description
 Layout 2 - Filleting line up to 20 fish/min.
 Description 2
 for salting/loading on racks to smoking

Scale: 1:200
 Format: A3
 File no.: 80033336
 Rev.: A

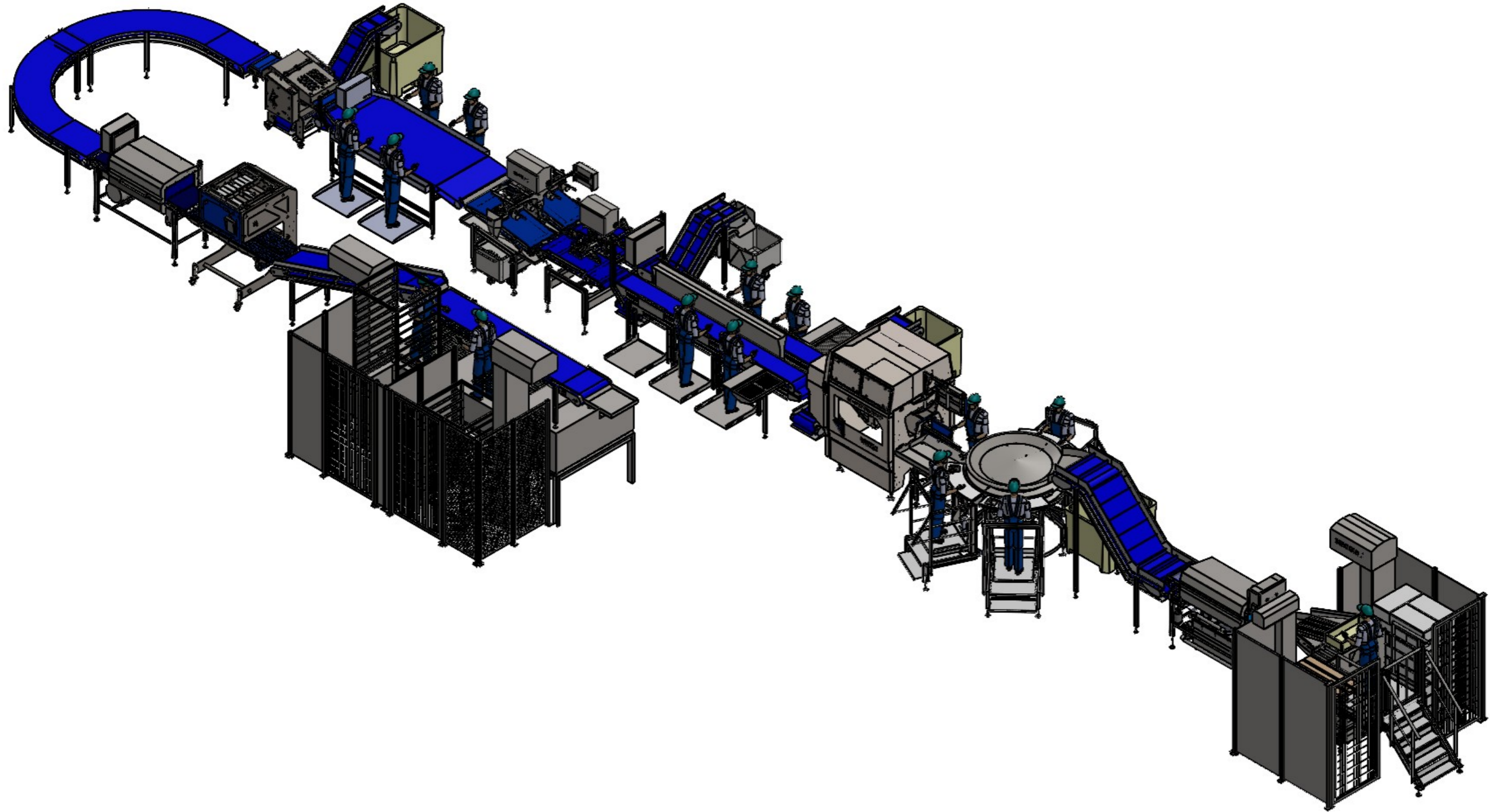

Finish	Polished	
	Pickled	
Foil	Inside	
	Outside	
Deburr		X

Notes

Proven Konzept Layout - Salmon.

Unless otherwise specified, all dimensions are in mm. and tolerances according to ISO 2768-1m
 General welding tolerance: DS/EN ISO 13920 - B
 This drawing is the property of Beritech A/S and may not be handed over to a third part, copied or in any other way applied without our authorization

BERITECH

Charge:

Drawn by: jbg **Edited by:** jbg

Material:

Drawn date: 2024-01-03

Weight (kg): 53180.41

Scale: 1:200

Description
 Layout 2 - Filleting line up to 20 fish/min.

Description 2
 for salting/loading on racks to smoking

File no.: 80033336 **Rev.:** A

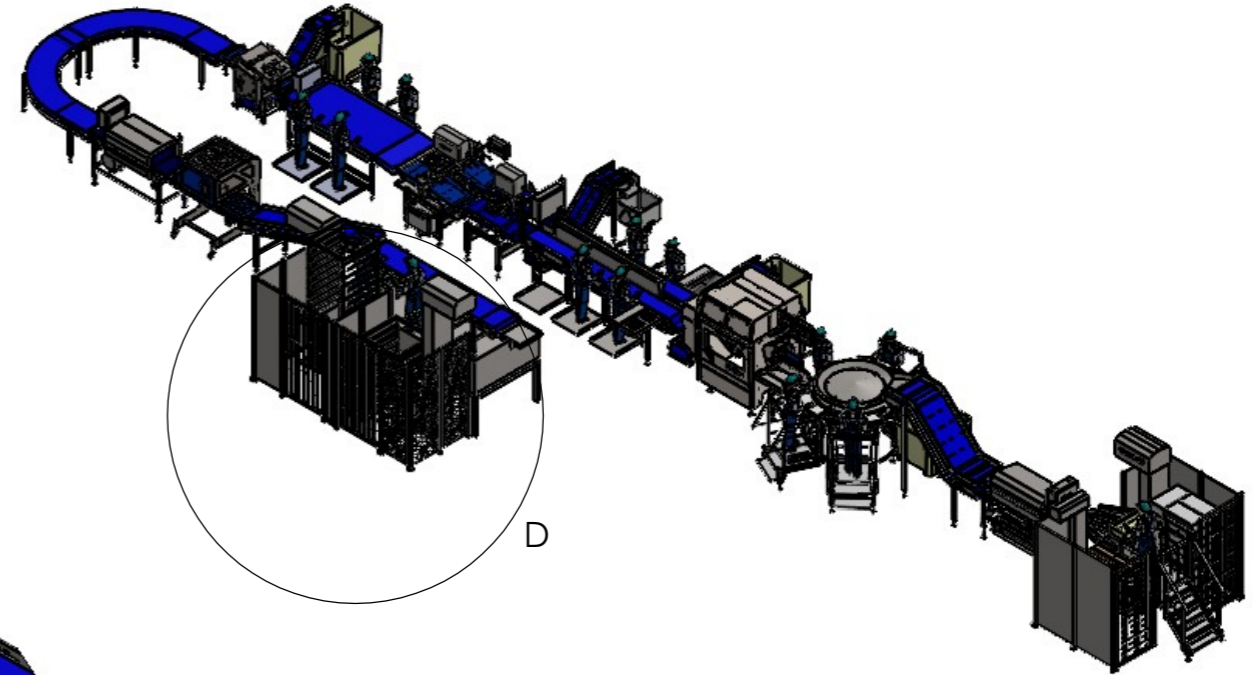
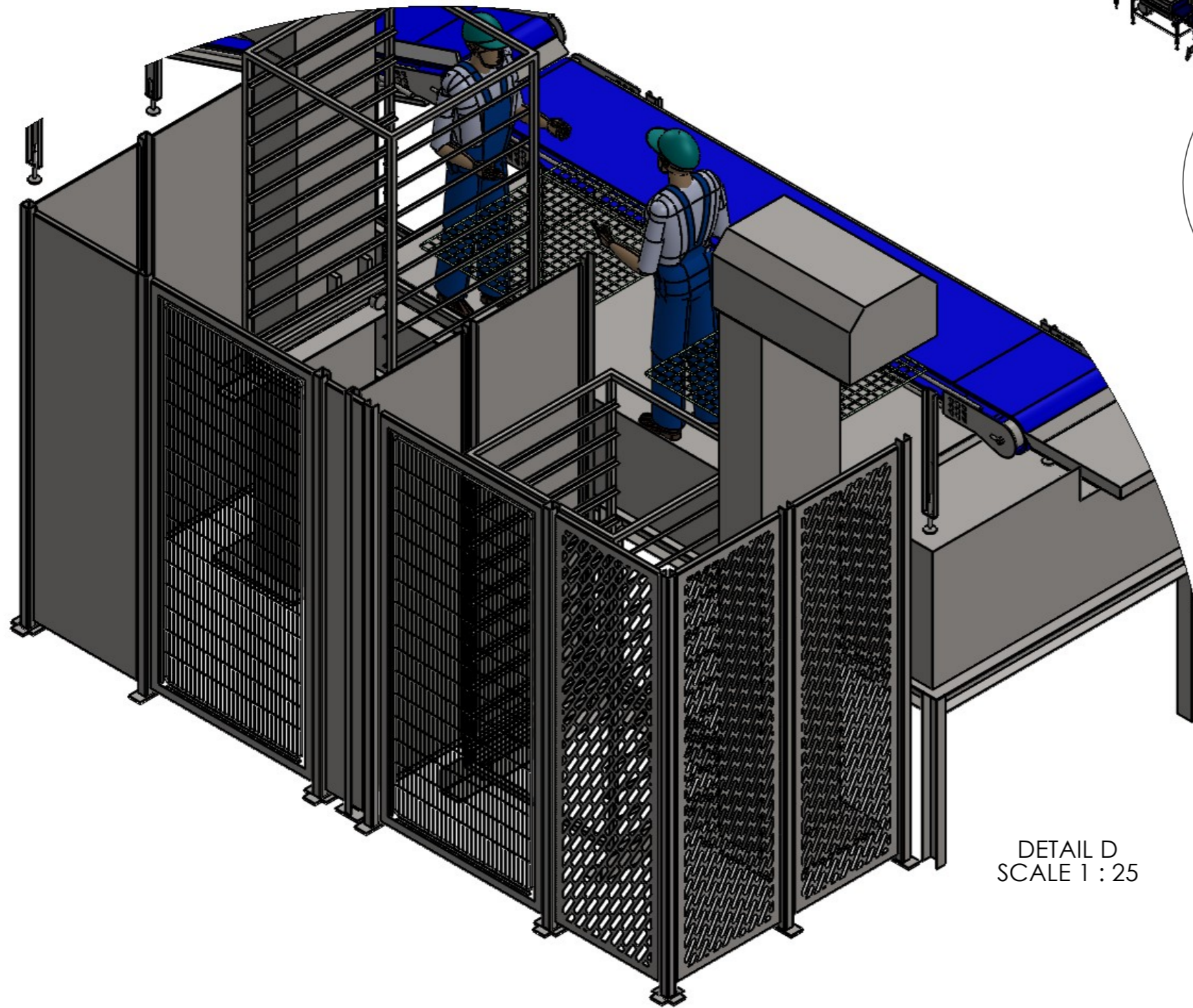

DETAIL D
SCALE 1 : 25

Finish	Polished	
	Pickled	
Foil	Inside	
	Outside	
Debur		X

Proven Concept Layout - Salmon.

Notes

Unless otherwise specified, all dimensions are in mm. and tolerances according to ISO 2768-1m
General welding tolerance: DS/EN ISO 13920 - B
This drawing is the property of Beritech A/S and may not be handed over to a third part, copied or in any other way applied without our authorization

BERITECH

Charge:
Drawn by: jbg
Edited by: jbg
Material:

Drawn date: 2024-01-03
Weight (kg): 53180.41
Scale: 1:200
Format: A3

Description
Layout 2 - Filleting line up to 20 fish/min.
Description 2
for salting/loading on racks to smoking
File no.: 80033336

Rev.: A

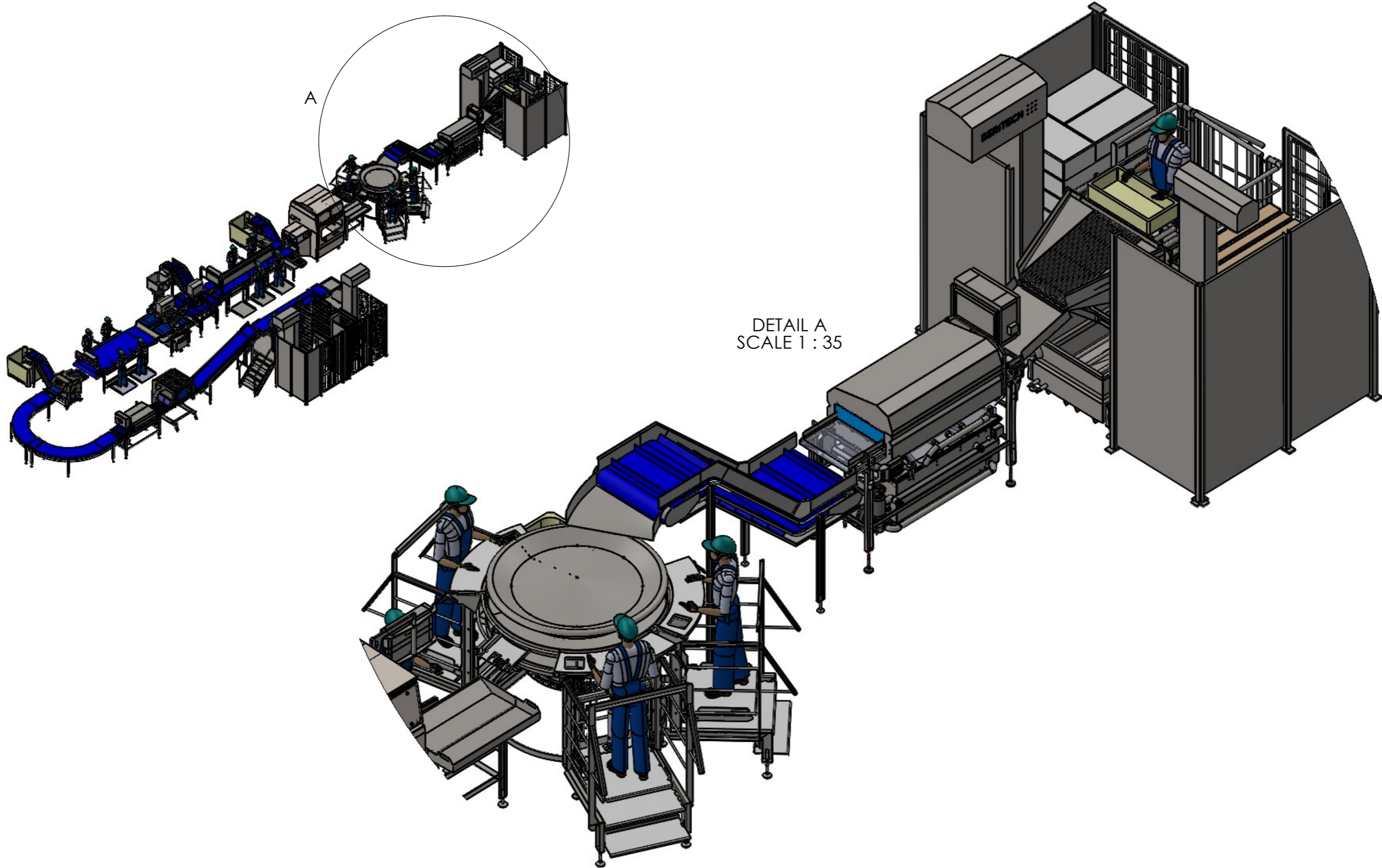

Finish	Polished	
	Pickled	
Foil	Inside	
	Outside	
Debur		X

Notes

Proven Conzept Layout - Salmon.

Unless otherwise specified, all dimensions are in mm. and tolerances according to ISO 2768-1m
 General welding tolerance: DS/EN ISO 13920 - B
 This drawing is the property of Beritech A/S and may not be handed over to a third part, copied or in any other way applied without our authorization

BERITECH

Charge:

Drawn by: jbg **Edited by:** jbg

Material:

Drawn date: 2024-01-03

Weight (kg): 53180.41

Scale: 1:200

Description
 Layout 2 - Filleting line up to 20 fish/min.

Description 2
 for salting/loading on racks to smoking

File no.: 80033336 **Rev.:** A

= Existing/3th. party equipment

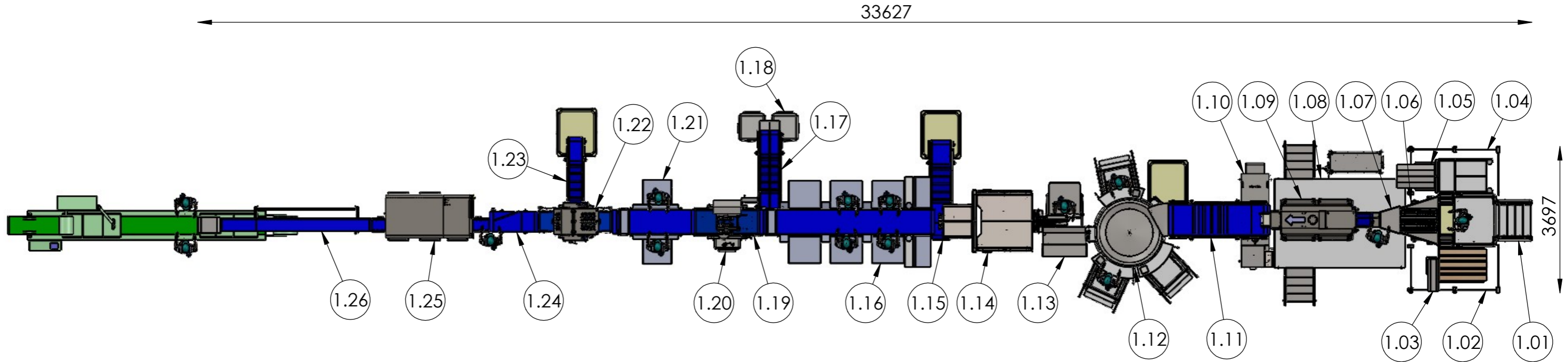

ITEM NO.	DESCRIPTION	QTY.
1.01	De-icing	1
1.02	Safety Fence - Left	1
1.03	Column loader CL300	1
1.04	Safety Fence Right	1
1.05	CL1000 Column loader for EUR pallets	1
1.06	Melting unit	1
1.07	Chute	1
1.08	Custom platform	1
1.09	DeScaler FD15 (inc. HP pump)	1
1.10	Filter unit for Descaler	1
1.11	Goose neck conveyor	1
1.12	DeHeading Table	1
1.13	Infeed Buffer Table	1

ITEM NO.	DESCRIPTION	QTY.
1.14	BE-5351 Compact Pro Filleting Machine	1
1.15	Goose neck conveyor	1
1.16	Trimming line	1
1.17	Goose neck conveyor	1
1.18	Trolley 200L	2
1.19	Pinbone Remover BE-5511 2-Lane	1
1.20	Filter Trolley 200L	1
1.21	Pin bone check	1
1.22	Beritech Salmon Skinner	1
1.23	Goose neck conveyor	1
1.24	Infeed conveyor	1
1.25	Portion Cutter 1 Lane	1
1.26	Conveyor for packing machine	1

Finish	Polished	
	Pickled	
Foil	Inside	
	Outside	
Deburr		X

Notes

Proven Conzept Layout - Salmon.

<small>Unless otherwise specified, all dimensions are in mm. and tolerances according to ISO 2768-1m</small> <small>General welding tolerance: DS/EN ISO 13920 - B</small> <small>This drawing is the property of Beritech A/S and may not be handed over to a third part, copied or in any other way applied without our authorization</small>		Charge:		Drawn date: 2026-04-07		Description Layout 3 - Filleting line up to 12 fish/min.	
		Drawn by: jbg	Edited by: jbg	Weight (kg): 94407.58		Description 2 for portioning and packing	
Material: Material <not specified>		Scale: >1:200	Format: A3	File no.: 80112778	Rev.: A		



= Existing/3th. party equipment

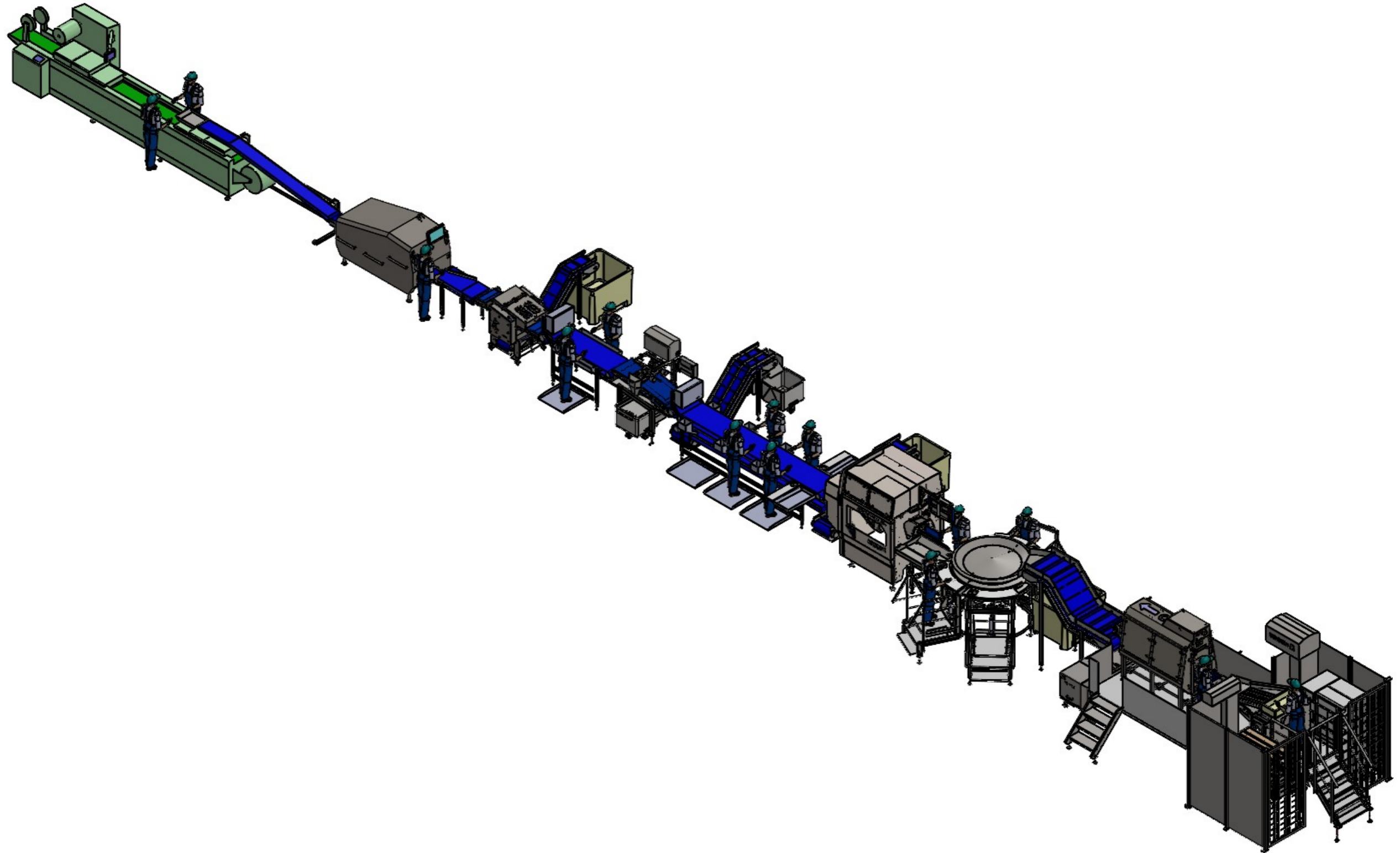

Finish	Polished	
	Pickled	
Foil	Inside	
	Outside	
Debur		X

Proven Conzept Layout - Salmon.

Notes

Unless otherwise specified, all dimensions are in mm. and tolerances according to ISO 2768-1m
 General welding tolerance: DS/EN ISO 13920 - B
 This drawing is the property of Beritech A/S and may not be handed over to a third part, copied or in any other way applied without our authorization

BERITECH

Charge:

Drawn by: jbg
Edited by: jbg
Material: Material <not specified>

Drawn date: 2026-04-07
Weight (kg): 94407.58
Scale: >1:200
Format: A3

Description
 Layout 3 - Filleting line up to 12 fish/min.
Description 2
 for portioning and packing
File no.: 80112778

Rev.: A

= Existing/3th. party equipment

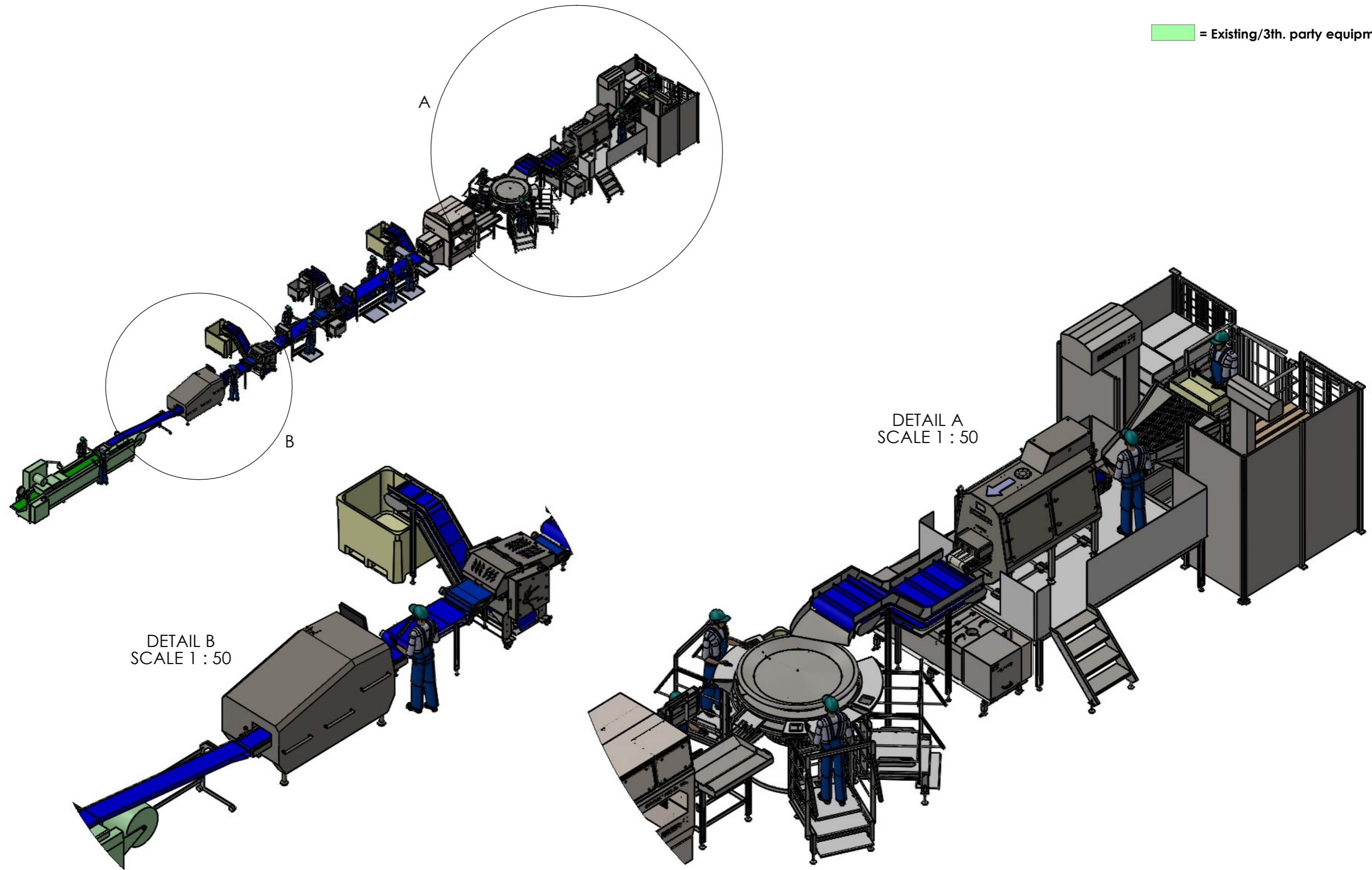

Finish	Polished	
	Pickled	
Foil	Inside	
	Outside	
Deburr		X

Notes

Proven Conzept Layout - Salmon.

<small>Unless otherwise specified, all dimensions are in mm. and tolerances according to ISO 2768-1m General welding tolerance: DS/EN ISO 13920 - B This drawing is the property of Beritech A/S and may not be handed over to a third part, copied or in any other way applied without our authorization</small>		Charge:		Drawn date: 2026-04-07		Description Layout 3 - Filleting line up to 12 fish/min.	
		Drawn by: jbg	Edited by: jbg	Weight (kg): 94407.58		Description 2 for portioning and packing	
Material: Material <not specified>		Scale: >1:200	Format: A3	File no.: 80112778	Rev.: A		



26697

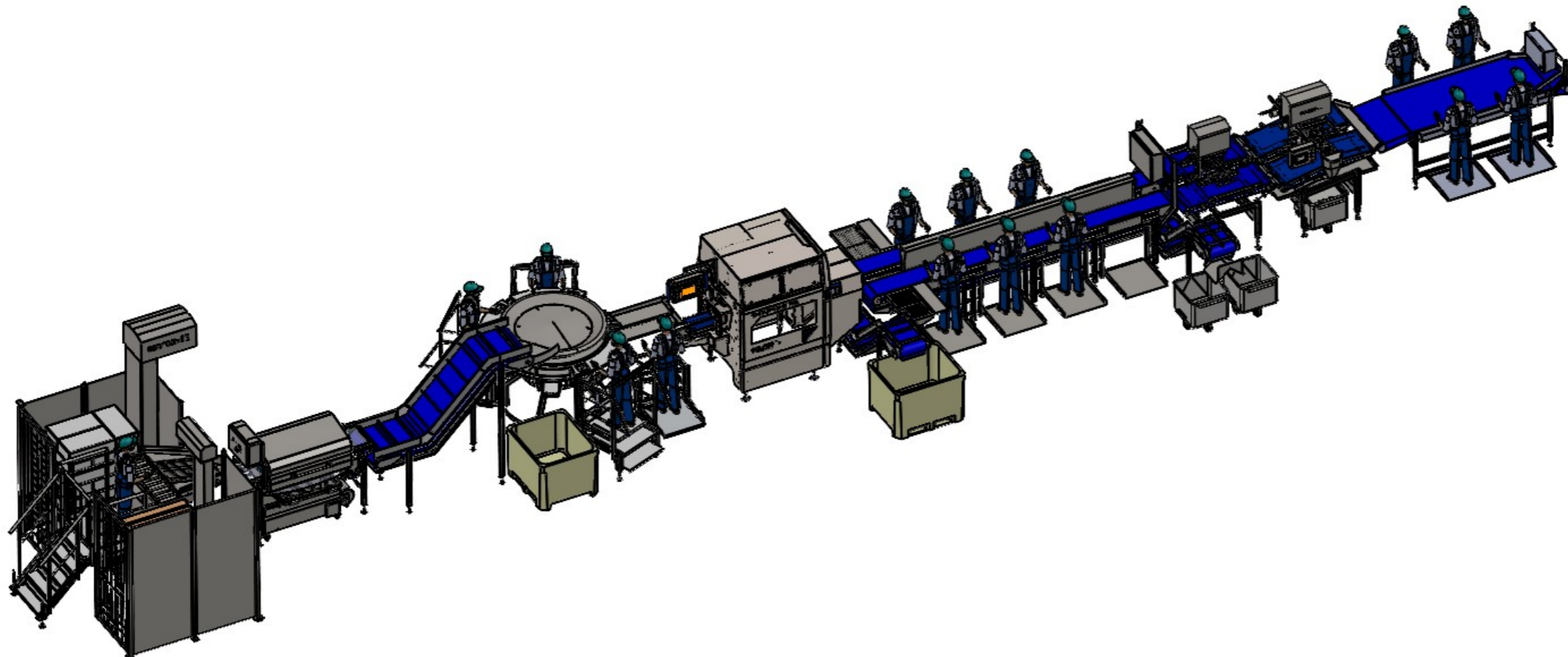
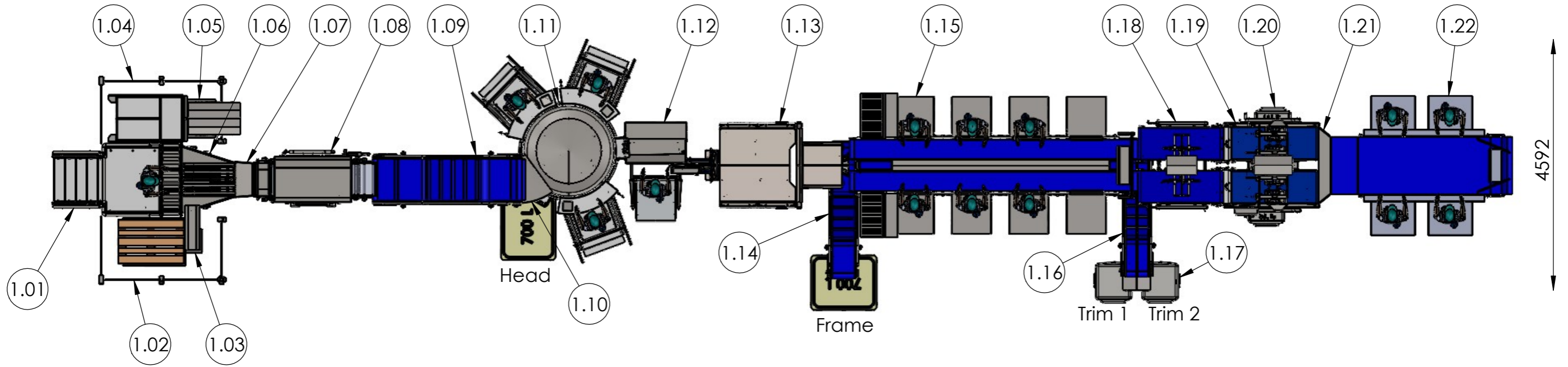

ITEM NO.	DESCRIPTION	QTY.
1.01	De-icing	1
1.02	Safety Fence Right	1
1.03	Column loader CL300	1
1.04	Safety Fence - Left	1
1.05	CL1000 Column loader	1
1.06	Melting unit	1
1.07	Chute symmetrical	1
1.08	Deslimer	1
1.09	Goose neck conveyor	1
1.10	Chute curved - Left	1
1.11	DeHeading Table	1
1.12	Platform for Fillet machine	1
1.13	Filleting Machine Compact Pro BE-5351	1
1.14	Goose neck conveyor	1
1.15	2-Lane Trimming Line	1
1.16	Goose neck conveyor	1
1.17	Trolley 200L	2
1.18	BE-5601 Fillet distributor	1
1.19	BE-5521 Pinbone Remover 4-Lane	1
1.20	Filter Trolley 200L	2
1.21	Chute after 4 lane Pb	1
1.22	Pin bone check	1

Finish	Polished	
	Pickled	
Foil	Inside	
	Outside	
Deburr		X

Notes

Proven Conzept Layout - Salmon.

Unless otherwise specified, all dimensions are in mm. and tolerances according to ISO 2768-1m
 General welding tolerance: DS/EN ISO 13920 - B
 This drawing is the property of Beritech A/S and may not be handed over to a third part, copied or in any other way applied without our authorization

BERITECH

Charge:

Drawn by: jbg

Material:

Drawn date: 2025-07-29

Edited by:

Scale: 1:200

Format: A3

Description
 Layout 5 - Filleting line up to 20 fish/min

Description 2

Weight (kg): 36634.72

File no.: 80089638

Rev.: A

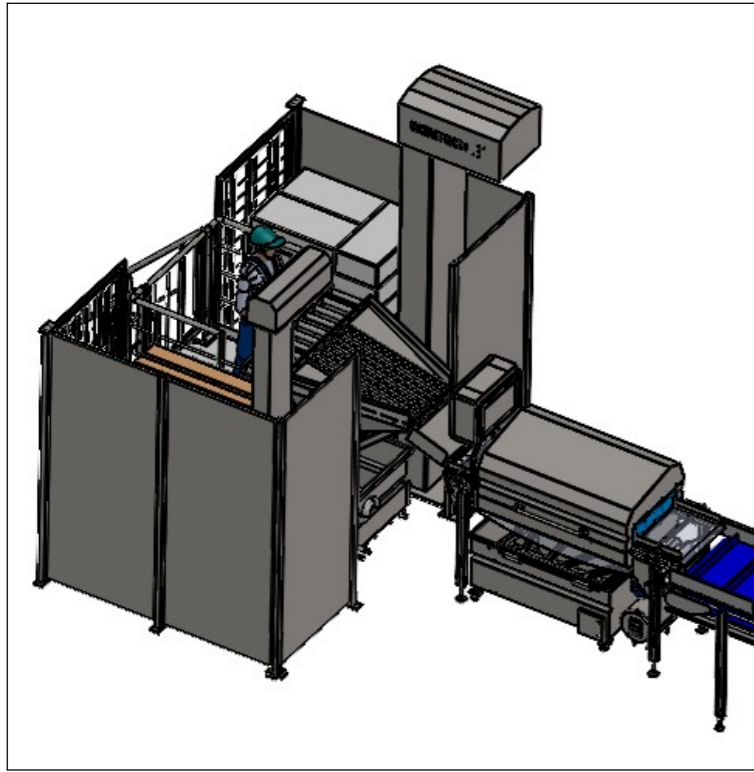

A

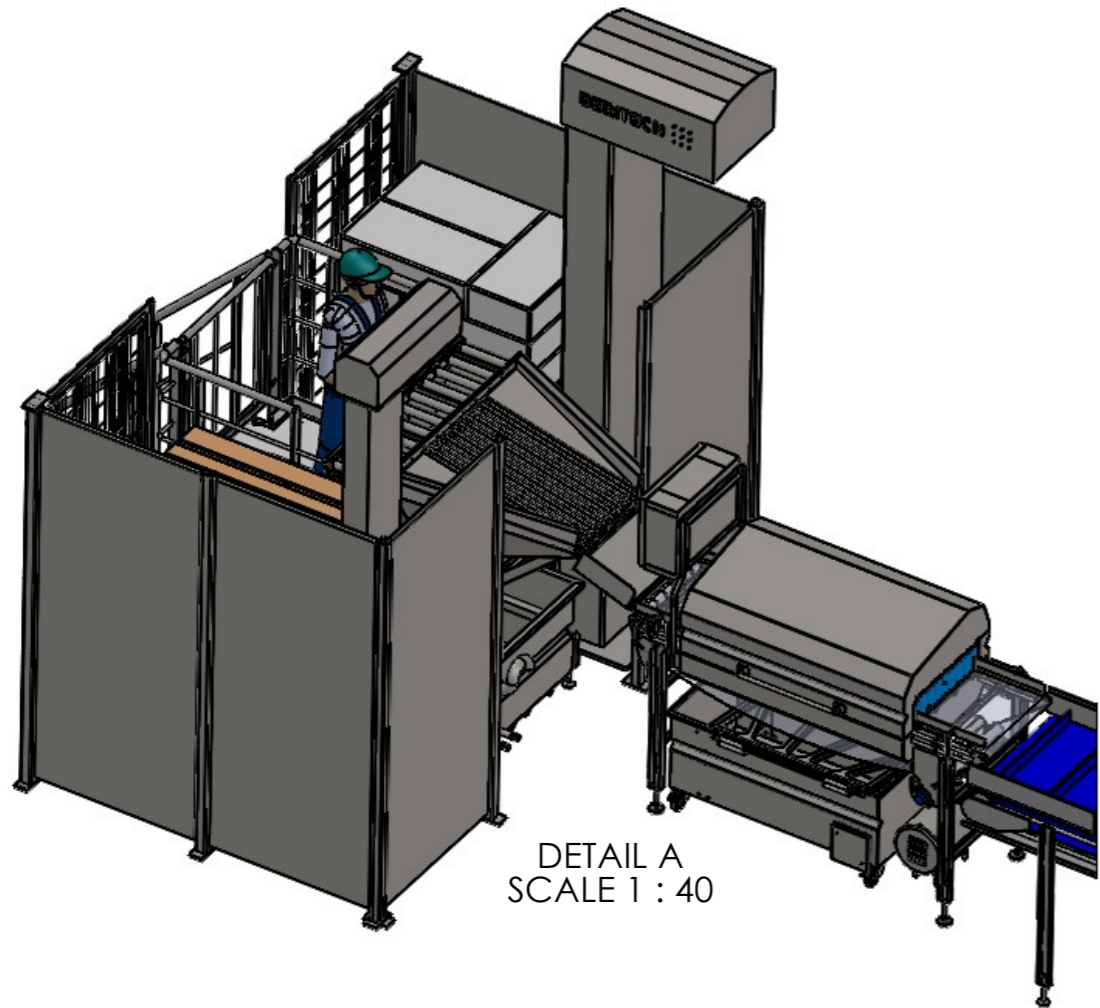
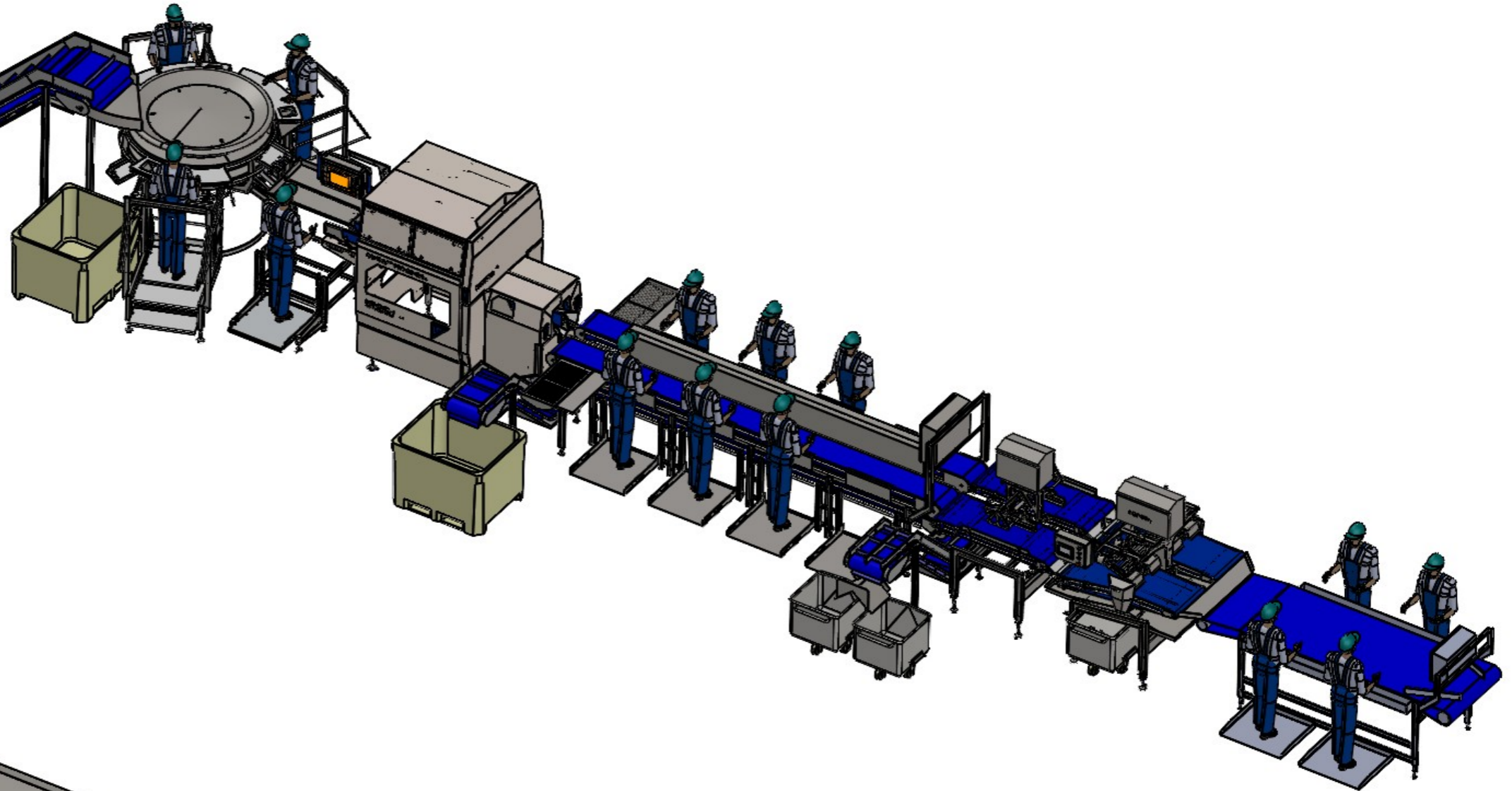

DETAIL A
SCALE 1 : 40

<small>Unless otherwise specified, all dimensions are in mm. and tolerances according to ISO 2768-1m General welding tolerance: DS/EN ISO 13920 - B This drawing is the property of Beritech A/S and may not be handed over to a third part, copied or in any other way applied without our authorization</small>		Charge: 	Drawn date: 2025-07-29	Description Layout 5 - Filleting line up to 20 fish/min	
Drawn by: jbg	Edited by: 	Weight (kg): 36634.72	Description 2 		
Material: 		Scale: 1:200	Format: A3	File no.: 80089638	Rev.: A

BERITECH

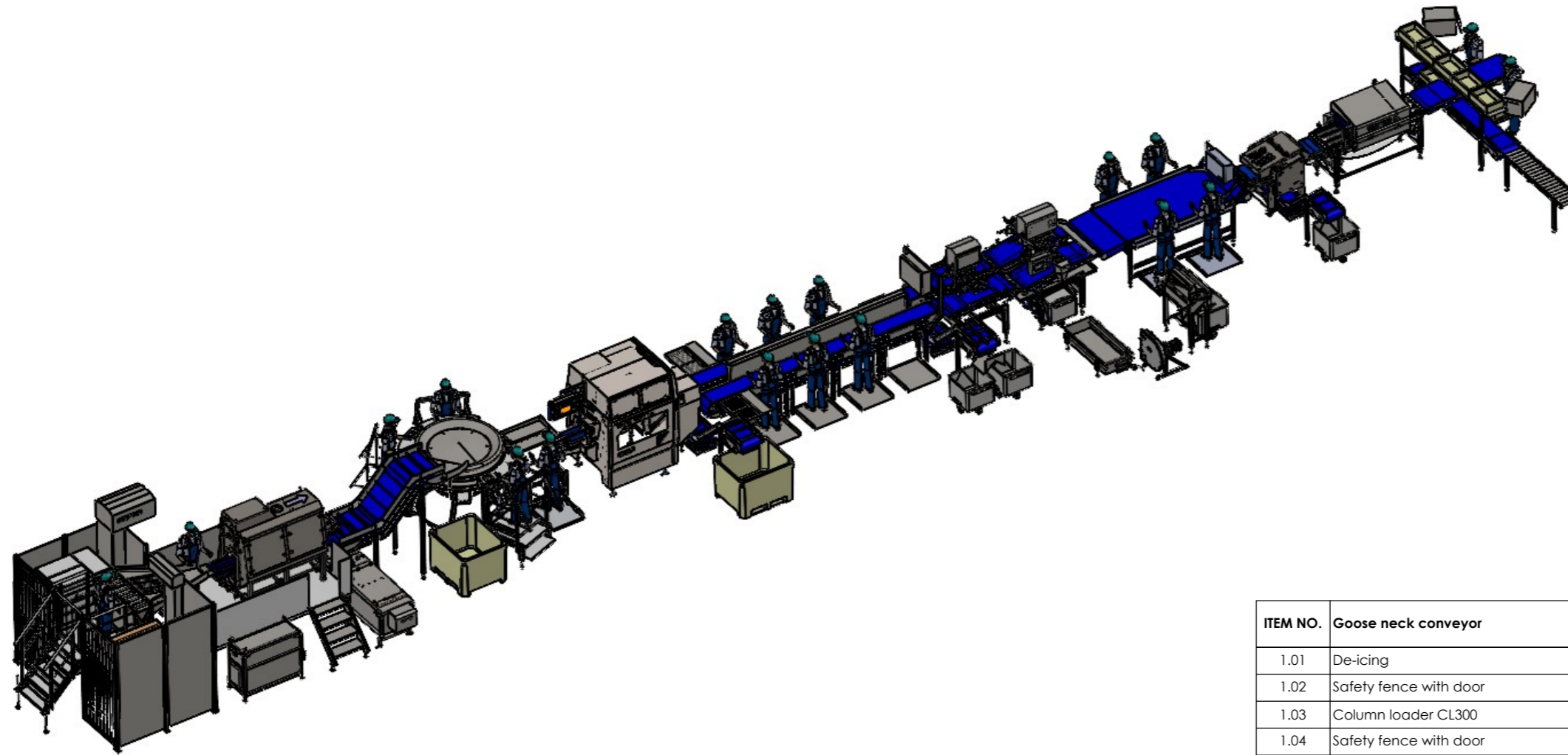
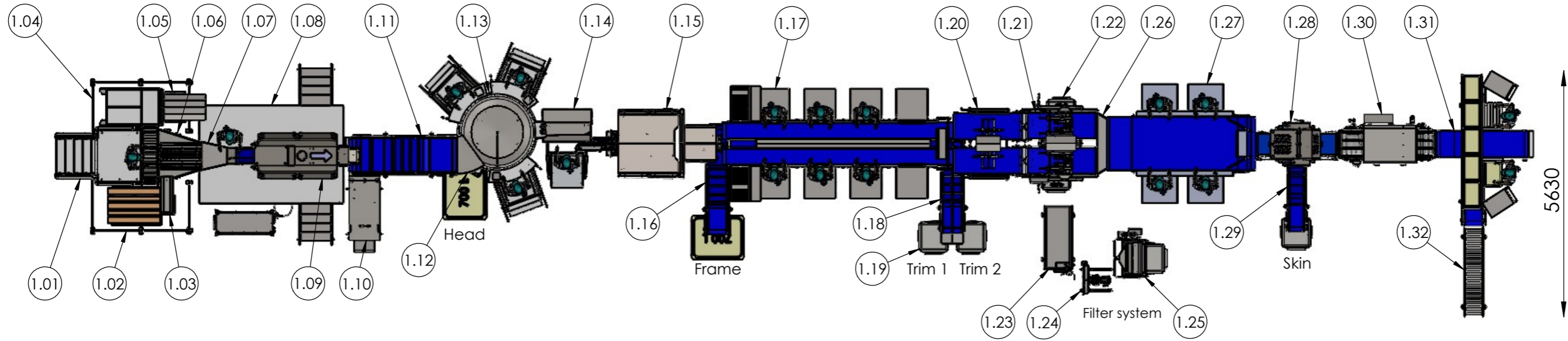

ITEM NO.	Goose neck conveyor	1
1.06	Melting unit	1
1.07	Chute symmetrical	1
1.08	Custom platform	1
1.09	DeScaler FD15 (inc. HP pump)	1
1.10	Filter unit for Descaler	1
1.11	Goose neck conveyor	1
1.12	Chute curved - Left	1
1.13	DeHeading Table	1
1.14	Platform for Fillet machine	1
1.15	Filleting Machine Compact Pro	1
1.16	Goose neck conveyor	1
1.17	2-Lane Trimming Line	1
1.18	Goose neck conveyor	1
1.19	Trolley 200L	4
1.20	Fillet distributor	1
1.21	Four lane pinboner	1
1.22	Filter Trolley 200L	2
1.23	Vessel for filter system	1
1.24	Hose pump	1
1.25	Filter unit	1
1.26	Chute after 4 lane Pb	1
1.27	Pin bone check	1
1.28	Beritech Salmon Skinner	1
1.29	Goose neck conveyor	1
1.30	Fillet Washer	1
1.31	Fillet Packing Station	1
1.32	Roller lane	1

ITEM NO.	Goose neck conveyor	1
1.01	De-icing	1
1.02	Safety fence with door	6
1.03	Column loader CL300	1
1.04	Safety fence with door	2
1.05	CL1000 Column loader	1

Finish	Polished	
	Pickled	
Foil	Inside	
	Outside	
Deburr		X

Notes

Proven Conzept Layout - Salmon.

Unless otherwise specified, all dimensions are in mm. and tolerances according to ISO 2768-1m
 General welding tolerance: DS/EN ISO 13920 - B
 This drawing is the property of Beritech A/S and may not be handed over to a third part, copied or in any other way applied without our authorization

BERITECH

Charge:

Drawn by: jbg **Edited by:** jbg

Material:

Drawn date: 2025-12-04

Weight (kg): 43223.00

Scale: 1:200 **Format:** A3

Description
 Layout 6 - Filleting line up to 20 fish/min

Description 2
 Fillet packing

File no.: 80102266 **Rev.:** A

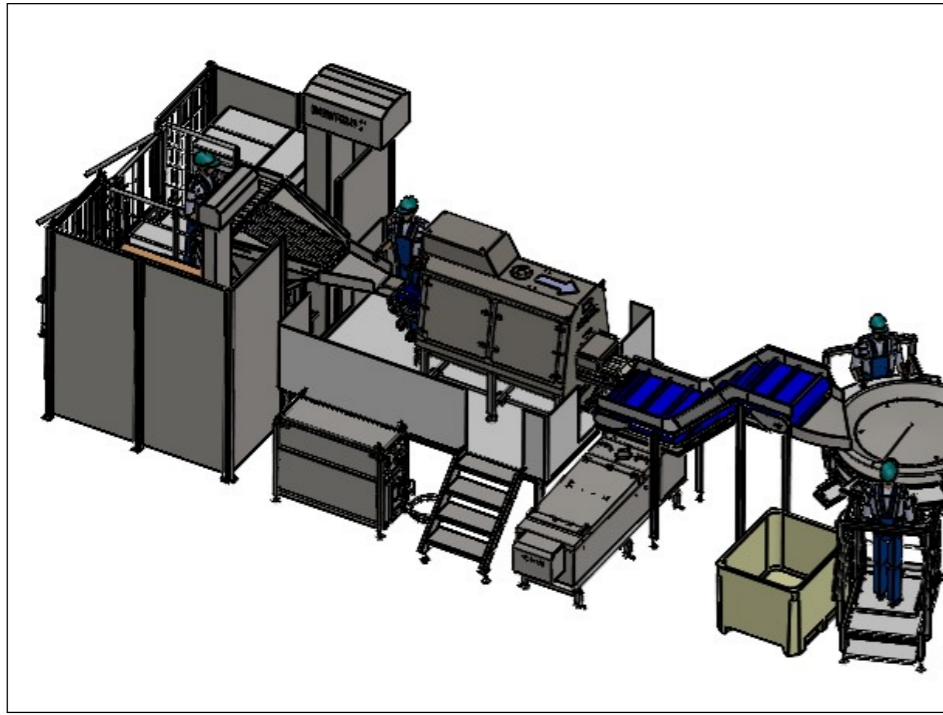

A

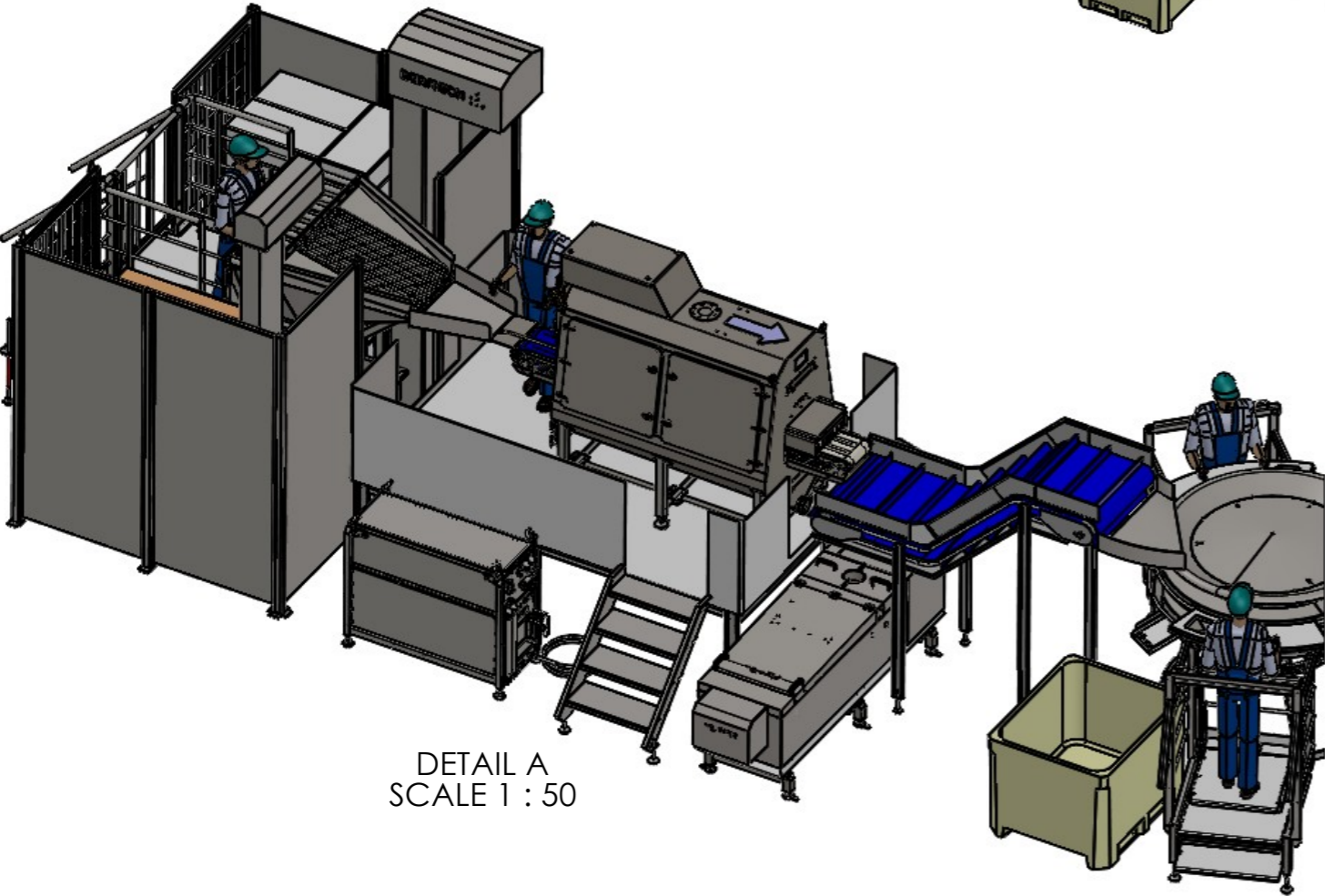
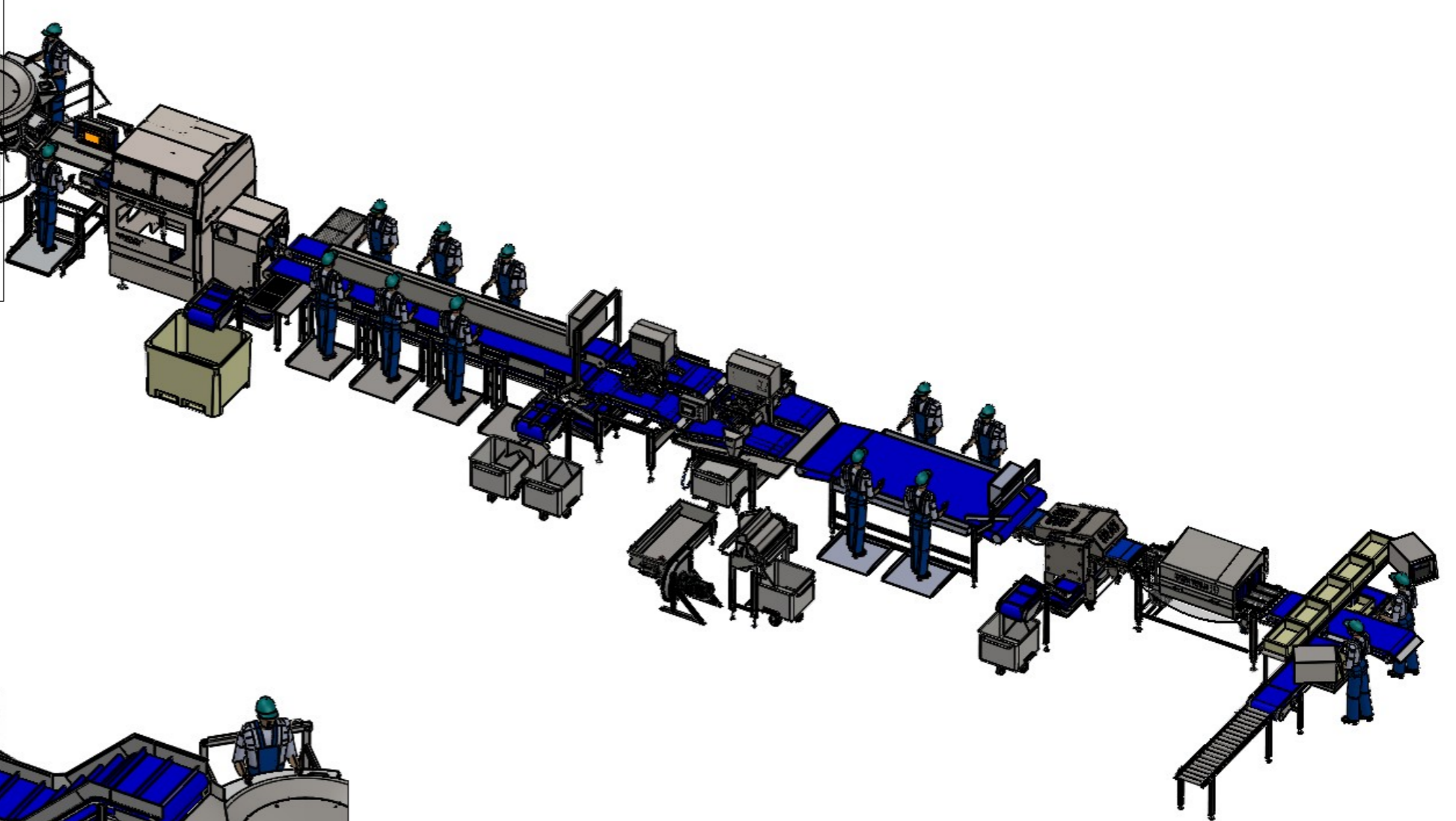

DETAIL A
SCALE 1 : 50

<small>Unless otherwise specified, all dimensions are in mm. and tolerances according to ISO 2768-1m General welding tolerance: DS/EN ISO 13920 - B This drawing is the property of Beritech A/S and may not be handed over to a third part, copied or in any other way applied without our authorization</small>	Charge:		Drawn date: 2025-12-04	Description Layout 6 - Filleting line up to 20 fish/min	
	Drawn by: jbg	Edited by: jbg	Weight (kg): 43223.00	Description 2 Filet packing	
	Material: Material <not specified>	Scale: >1:200	Format: A3	File no.: 80102266	Rev.: A

BERITECH